

Visible Signals

Gainbrain

DIY Video Synthesizer module for Eurorack

Manual V0.2b



The Gainbrain is a flexible video-rate crossfader, VCA and two- or four-quadrant analog voltage multiplier.

All Visible Signals manuals include a version number, which corresponds to the version number printed on the PCBs, plus a revision letter. Please make sure the manual you use has the same version number as your PCBs! Contact info@visiblesignals.net if you can't find the right manual.

Suggested Build Order – Gainbrain

RESISTORS

<u>Part</u>	<u>Value</u>	<u>Part</u>	<u>Value</u>
<input type="checkbox"/> R14	100K	<input type="checkbox"/> R28	1K
<input type="checkbox"/> R15	100K	<input type="checkbox"/> R1	1K5
<input type="checkbox"/> R16	100K	<input type="checkbox"/> R8	1K5
<input type="checkbox"/> R17	100K	<input type="checkbox"/> R10	1K5
<input type="checkbox"/> R18	100K	<input type="checkbox"/> R3	4.99K
<input type="checkbox"/> R22	100K	<input type="checkbox"/> R7	4.99K
<input type="checkbox"/> R2	10K	<input type="checkbox"/> R12	4.99K
<input type="checkbox"/> R5	10K	<input type="checkbox"/> R9	499R
<input type="checkbox"/> R6	10K	<input type="checkbox"/> R11	499R
<input type="checkbox"/> R24	10K	<input type="checkbox"/> R19	499R
<input type="checkbox"/> R26	10K	<input type="checkbox"/> R21	499R
<input type="checkbox"/> R4	10K	<input type="checkbox"/> R23	499R
<input type="checkbox"/> R20	1K	<input type="checkbox"/> R27	499R
<input type="checkbox"/> R25	1K	<input type="checkbox"/> R13	665R

DIODES & FERRITES

Make sure the diodes are in the right way.

<u>Part</u>	<u>Value</u>	<u>Part</u>	<u>Value</u>
<input type="checkbox"/> D1	1N400x	<input type="checkbox"/> L1	Ferrite Bead
<input type="checkbox"/> D2	1N400x	<input type="checkbox"/> L2	Ferrite Bead

INTEGRATED CIRCUITS

Make sure the ICs are in the right way, with the notch (or the left side relative to the writing on top of the chip) lined up with the silkscreen.

<u>Part</u>	<u>Value</u>	<u>Part</u>	<u>Value</u>
<input type="checkbox"/> IC1	TL072	<input type="checkbox"/> IC3	LM6172
<input type="checkbox"/> IC2	LT1256/LT1251	<input type="checkbox"/> IC4	LM6172

MLCC CAPACITORS

All unlabelled capacitors on the PCB silkscreen are 100nF MLCC types.

<u>Part</u>	<u>Value</u>	<u>Part</u>	<u>Value</u>
<input type="checkbox"/> C3	100n	<input type="checkbox"/> C7	100n
<input type="checkbox"/> C4	100n	<input type="checkbox"/> C8	100n
<input type="checkbox"/> C5	100n	<input type="checkbox"/> C9	100n
<input type="checkbox"/> C6	100n	<input type="checkbox"/> C10	100n

SOCKETS

Make sure the sockets fit into the front panel as you solder them.

<u>Part</u>	<u>Value</u>	<u>Part</u>	<u>Value</u>
<input type="checkbox"/> CV	WQP-PJ301M-12_JACK	<input type="checkbox"/> IN2	WQP-PJ301M-12_JACK
<input type="checkbox"/> IN1	WQP-PJ301M-12_JACK	<input type="checkbox"/> OUT	WQP-PJ301M-12_JACK

POTS

Make sure the pots fit into the front panel as you solder them.

<input type="checkbox"/>	<u>Part</u>	<u>Value</u>	<input type="checkbox"/>	<u>Part</u>	<u>Value</u>
	VR1	B10K		VR2	B10K

VOLTAGE REFERENCE

Make sure the flat side of the TL431 voltage reference is oriented the same way as shown on the silkscreen. Bend the middle pin out slightly so it goes into the correct hole.

<input type="checkbox"/>	<u>Part</u>	<u>Value</u>
	REG1	TL431

ELECTROLYTIC CAPACITORS

Make sure the long legs go in the hole marked with a '+'.
Make sure the long legs go in the hole marked with a '+'.

<input type="checkbox"/>	<u>Part</u>	<u>Value</u>	<input type="checkbox"/>	<u>Part</u>	<u>Value</u>
	C1	10uF		C2	10uF

POWER HEADER

Make sure the notch on the shrouded power header is on the outside edge of the PCB.

<input type="checkbox"/>	<u>Part</u>	<u>Value</u>
	POWER	5x2 Pin Header

SWITCH SHIM PCB

Make sure the shim PCB has the **Top** side facing out, away from the switch, or else the 2Q/4Q switch will work backwards! Solder the switch shim PCB to the main PCB first, then attach the switch to the panel, then put the socket and pot nuts on to hold the panel in place and finally solder the switch to the shim PCB.

<input type="checkbox"/>	<u>Part</u>	<u>Value</u>
	PCB	1PDT

Circuit Details

The heart of the Gainbrain is the handy LT1256/LT1251 chip from Analog Devices, with a circuit diagram based on the datasheet examples. The two inputs IN1 and IN2 are unity-gain buffered, with a SPDT switch to connect the IN1 signal to the FB2 pin for a 4-quadrant multiplier mode (as described in the LT1251 datasheet).

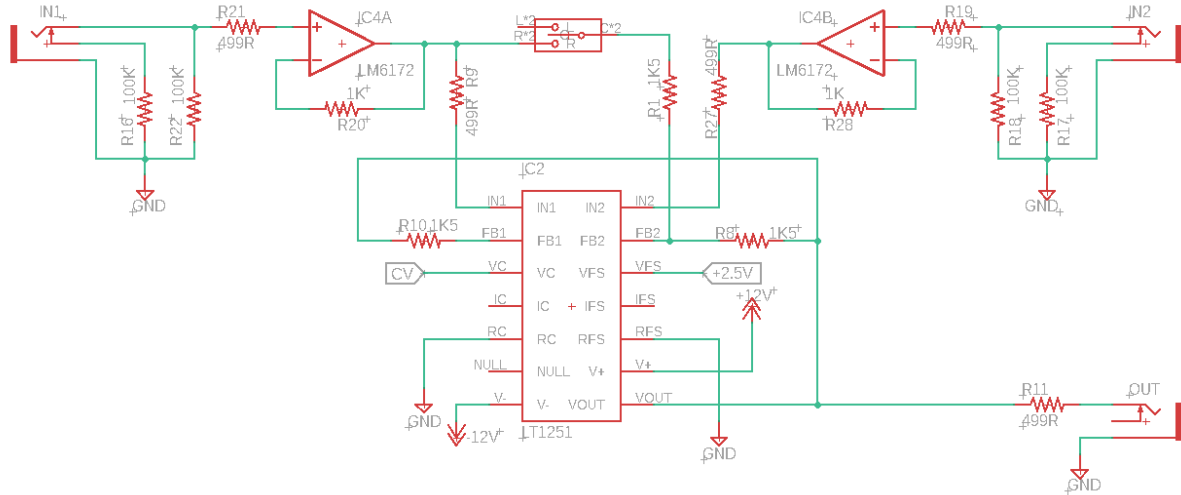

The +2.5V reference for the LT1251/LT1256 is generated by a TL431, and some LM6172 op-amps provide manual offset and scaling controls for the CV input. R13 sets the gain of the CV input and VR1 attenuates and/or inverts it. Similarly, IC1A and VR2 give a bipolar manual offset for the CV.

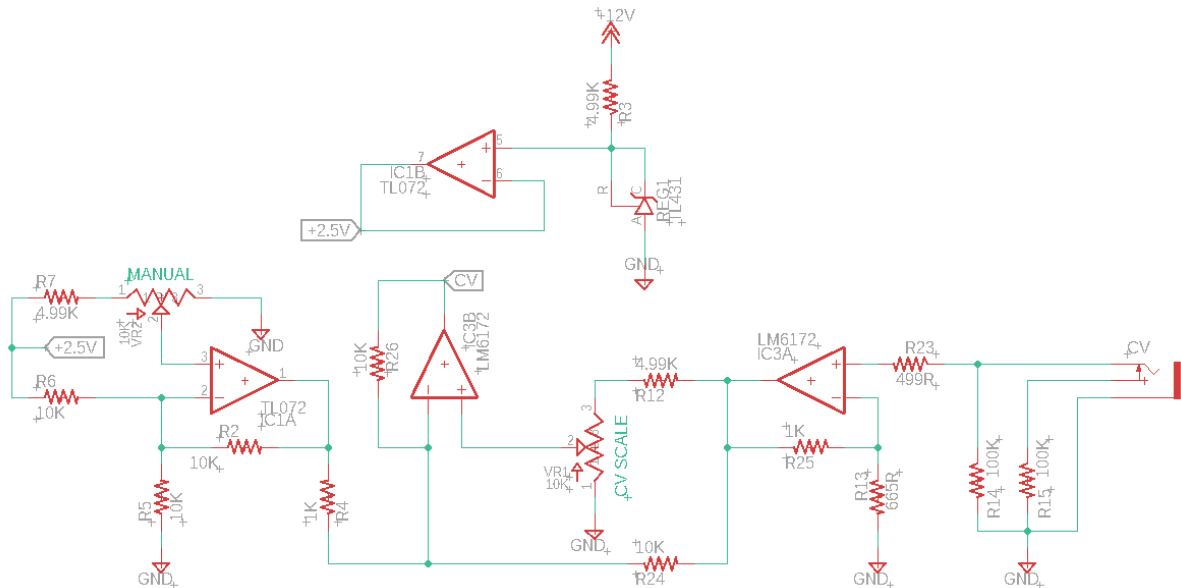

The LT1256 works approximately linearly from 0% to 100% VC input, which is preferable for voltage multiplier tasks (use the IN1 and CV inputs for this). The LT1251 has a 'snap to zero' function as it approaches 0% and 100%, which introduces a small error when used for linear multiplication.

However, that 'snap to zero' function in the LT1251 makes it perfect for VCA (CV input sets the gain of IN1, or the inverse gain of IN2) and crossfading duties (CV controls crossfade from IN1 to IN2) since a slightly non-zero CV signal input won't result in a 'ghosted' IN1 or IN2 signal source leaking through to the output.

Bill of Materials

Parts marked with an asterisk are frequently used in Visible Signals modules, so consider stocking up if there's a quantity discount available.

<u>Type</u>	<u>Value/Description</u>	<u>Qty</u>	<u>Vendor</u>	<u>Part Number</u>	<u>*</u>	<u>Notes</u>
MLCC Capacitor	100n	8	Mouser	594-K104K15X7RF53K2	*	
Diode	1N400x	2	Mouser	750-1N4001-G	*	Any part like 1N4001, 1N4004, etc is fine
Electrolytic Capacitor	10uF	2	Mouser	80-ESL106M050AC3AA	*	
Ferrite bead	Ferrite bead	2	Mouser	623-2743001111	*	
IC	TL072	1	Mouser	595-TL072IP	*	
IC	LT1256 (or LT1251)	1	Mouser	584-LT1256CN#PBF		Use LT1251 if you don't need a multiplier
IC	LM6172	2	Mouser	926-LM6172IN/NOPB	*	
PCB	Gainbrain PCB set	1	Visible Signals	GABR		
Panel	Gainbrain PCB set	1	Visible Signals	GABR		
Pin Header	Pin header 5x2	1	Mouser	710-61201021621	*	Shrouded
Knobs	Davies 1900H	2	Thonk	1900H	*	T18 or rounded shaft to match Pots
Potentiometer	10K Linear	2	Thonk	Alpha 9mm right-angled		T18 or rounded shaft to match Knobs
Resistor	1.5K	3	Mouser	603-MFR-25FBF52-1K5		
Resistor	100K	6	Mouser	603-MFR-25FBF52-100K	*	
Resistor	10K	6	Mouser	603-MFR-25FBF52-10K	*	
Resistor	1K	3	Mouser	603-MFR-25FBF52-1K	*	
Resistor	4.99K	3	Mouser	594-5063JD4K990F		
Resistor	499R	6	Mouser	594-5063JD499R0F	*	
Resistor	665R	1	Mouser	594-5063JD665R0F		
Socket	PJ302M	4	Thonk	PJ302M	*	
Switch	1PDT ON-ON Toggle	1	Mouser	118-1MS1T1B1M1QES		
Voltage Reference	TL431	1	Mouser	511-TL431CZT	*	